

**51 16 200 Removing and installing center console**

[Remove bottom right trim panel from instrument panel.](#)

[Remove trim panel for pedal assembly.](#)

[Remove switch for hazard warning system/central locking.](#)

[Remove switch unit in center console.](#)

[Release center console at rear.](#)

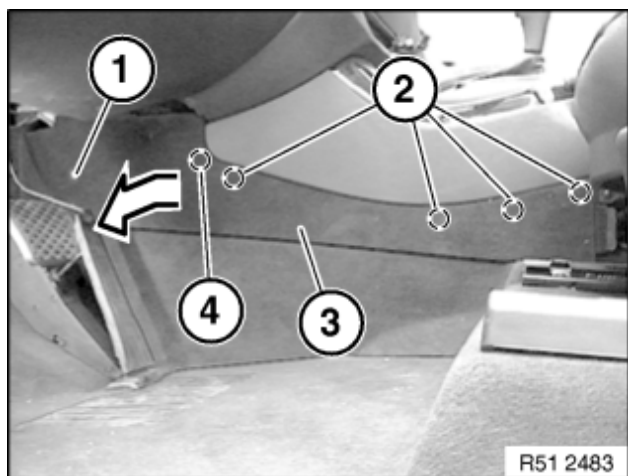

Release left/right screws (1).

Unclip clips (2) outwards on side carpet (3) on left/right.

Slide side carpet (3) forwards out of retainer (4) and remove.

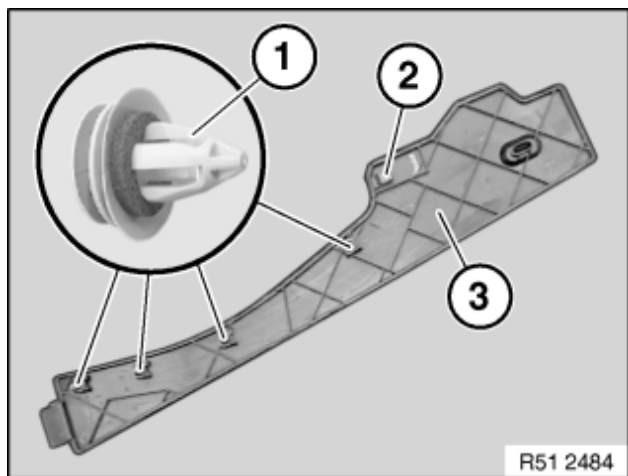

*Installation:*

If necessary, replace faulty clips (1) with sealing washer and retainer (2) on side carpet (3).

Release screw (1).

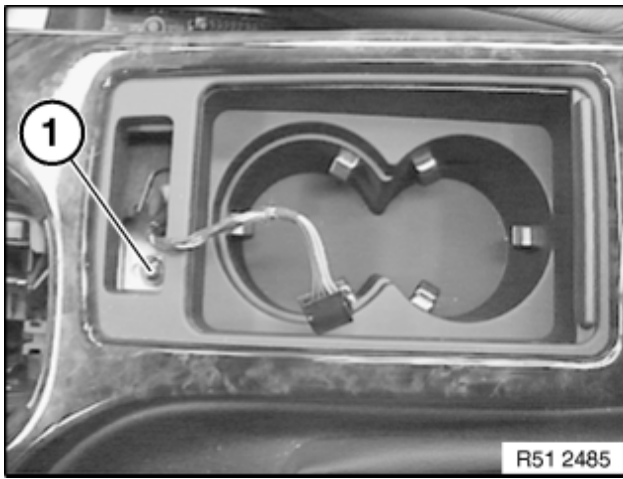

Release left/right screws (1).  
Disconnect plug connections (2).

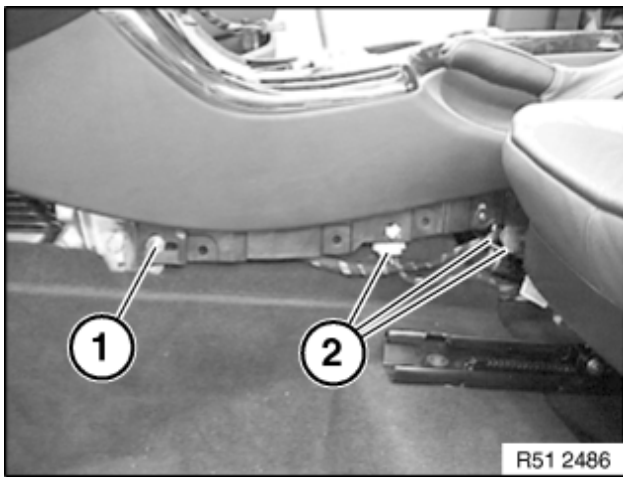

Apply handbrake lever (1) to max. setting.  
Unclip rubber gaiter (2).  
Raise center console (3) at rear and lift over handbrake lever (1).

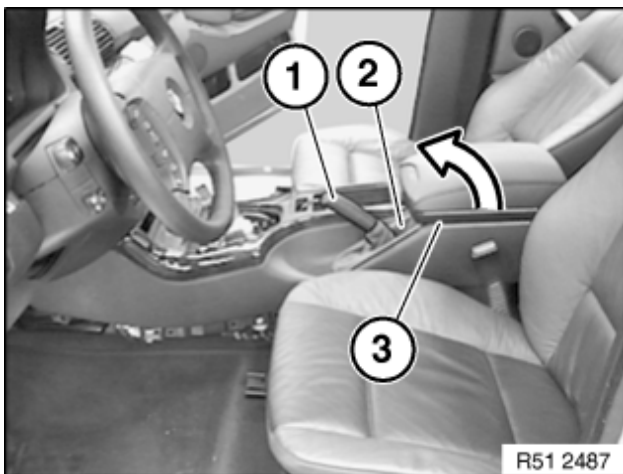

Feed plug (2) out of center console (3).  
Lift center console (3) over shift stick (4) and remove from car.

**Installation:**

Guides (1) must not be damaged.

